Virtualized Oracle 11g/R2 RAC Database on Oracle VM: Methods/Tips



OTN South America Tour 2011
Brazil, Uruguay and Chile, July 2011.

Kai Yu



Oracle Solutions Engineering
Dell Inc

About Author

- Kai Yu, *kai_yu@dell.com*
 - 16 years with Oracle Technology
 - Focus on Oracle RAC, Oracle VM and Oracle EBS
 - Oracle ACE Director, author and frequent presenter
 - IOUG Oracle RAC SIG President (2009-2010)
 - IOUG Virtualization Committee Member
 - 2011 OAUG Innovator of Year Award Winner
 - Oracle Blog: <http://kyuoracleblog.wordpress.com/>
- Dell Oracle Solutions Engineering: www.dell.com/oracle
 - Oracle Technology Solutions on Dell systems/storages
 - Dell | Oracle Solutions Components
 - Solutions stack: servers, storage, network, OS, virtualization, Oracle RAC, Oracle Applications

Agenda

- ❖ **Introduction to Oracle VM and Oracle RAC**
- ❖ **Establishing Oracle VM Infrastructure**
- ❖ **Configuring Oracle guest VMs for RAC**
- ❖ **Configuring 11g R2 RAC database on Oracle VM**
- ❖ **Provision 11g R2 RAC with EM Provisioning PACK**
- ❖ **Recorded Demo: Oracle 11g RAC on Oracle VM**

Introduction to Oracle VM and RAC

- **Introduction of Oracle VM Virtualization Solution.**
 - Software based server Virtualization solutions for X86
 - Server partitions and consolidation
 - High availability and scalability
 - Fast deployment and standardization
 - Provide the virtualization support for Grid /Cloud
- **Oracle VM Architecture**
 - Oracle VM server: Xen Hypervisor, management Linux kernel with support of devices, IO, networking, etc.
 - VM: guest OS with applications running on domU

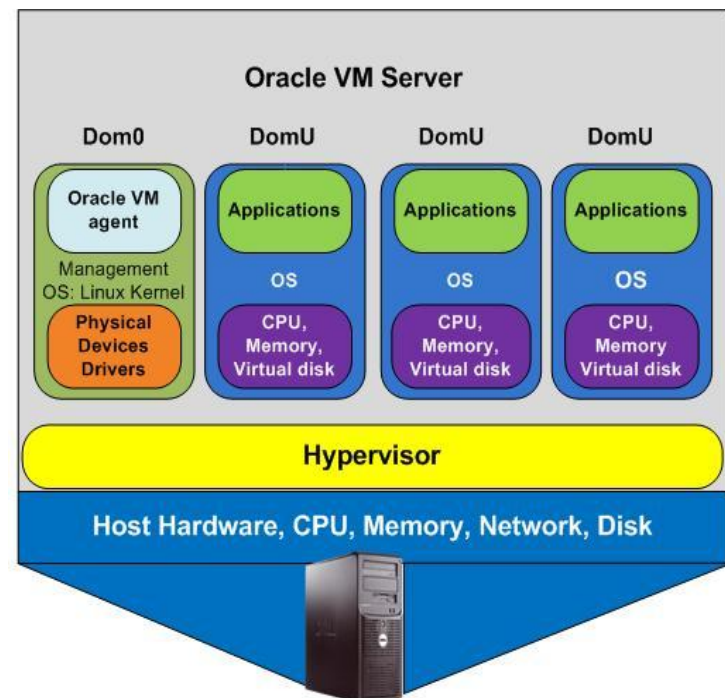

Introduction to Oracle VM and RAC

Virtual Server Pool: an autonomous region of VM servers

Oracle VM Manager: GUI Management solution for Oracle VM

Oracle VM Agent: installed with VM server and communicating with Oracle VM manager

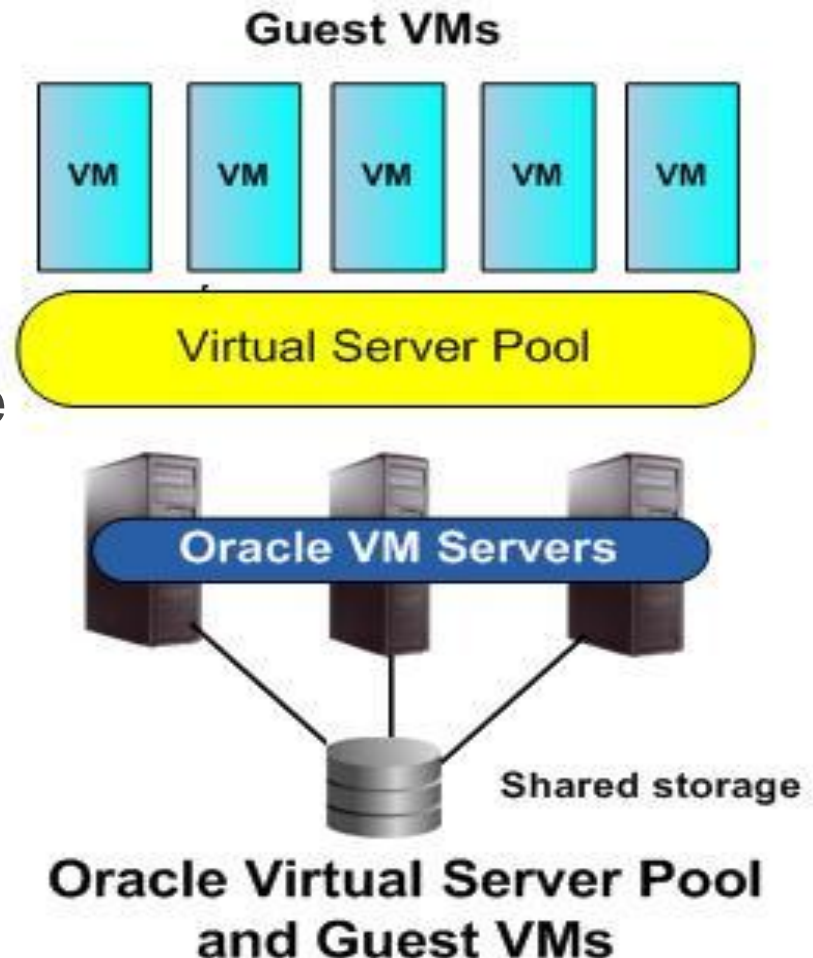

Introduction to Oracle VM and RAC

- Oracle Real Application Clusters (RAC)
 - Multiple instances running interconnected by high speed private network share a single database
 - Oracle Cache Fusion Technology for node synchronization
 - All Instances can execute transactions simultaneously on the single database in the shared storage
 - High Availability and scalability for the applications

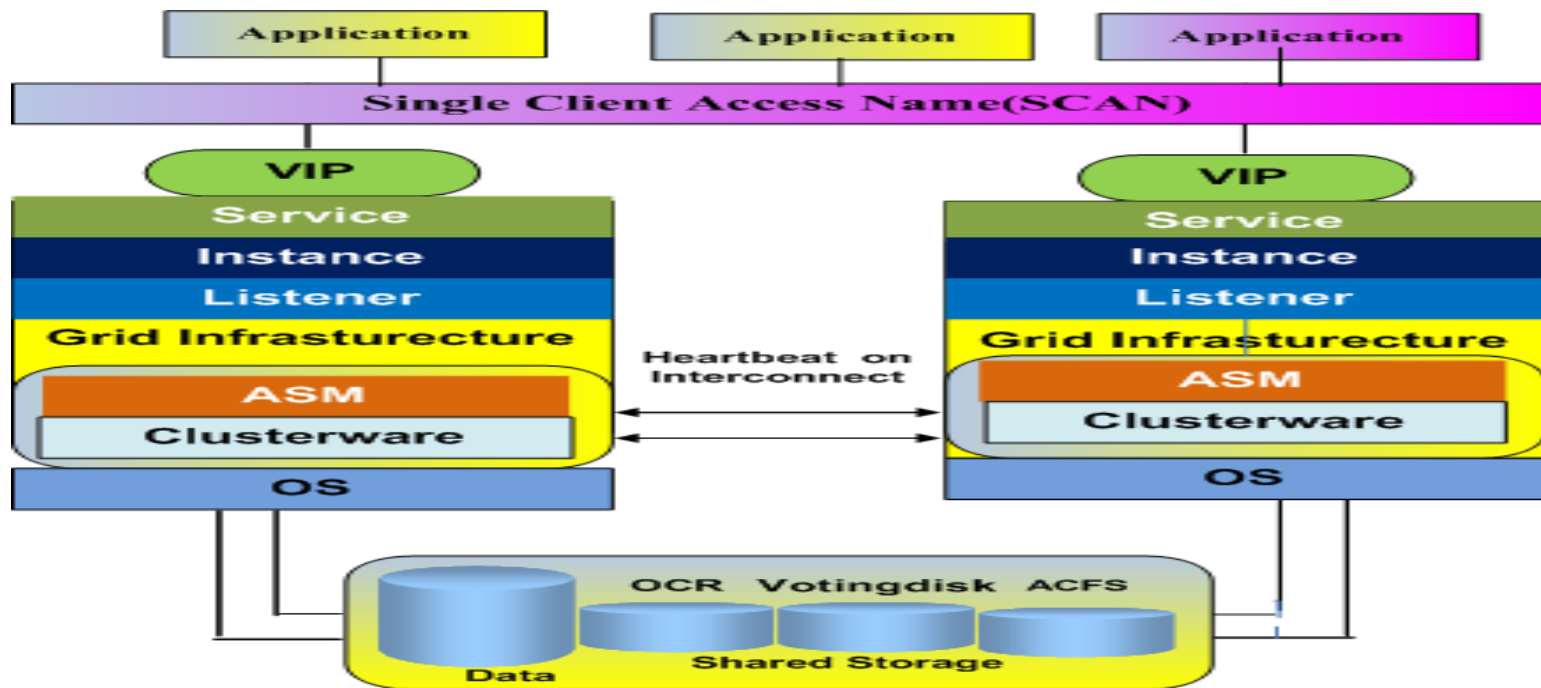

Introduction to Oracle VM and RAC

- Why running RAC On Oracle VM
 - Server partition and consolidation
 - Sub-capacity licensing
 - Virtual cluster on single physical server
 - Template base deployment

Oracle VM

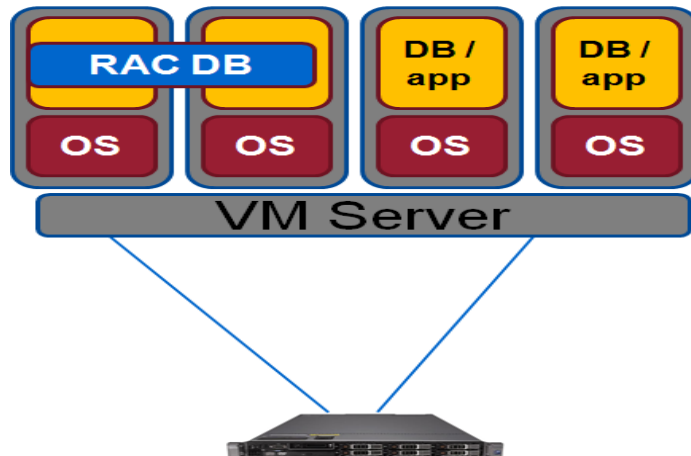

- Oracle VM
- Partitioning single server
- Consolidation
- Development/Test RAC

Oracle RAC on Oracle VM

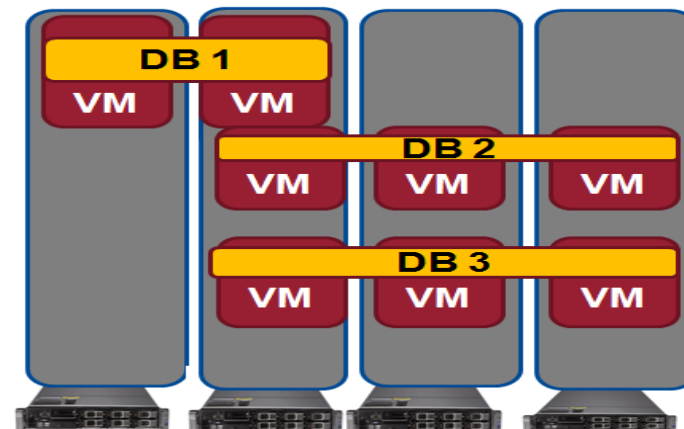

- Server partitioning and clustering
- Scale-up and scale-out
- Production RAC

Introduction to Oracle VM and RAC

- Deployment Method of RAC On Oracle VMs
 - Guest VMs as Oracle RAC Nodes
 - Multiple guest VMs running on Oracle VM servers
 - All the network and storage go through VM servers
 - Configuration of network & shared storage on VM servers and VMs?

11g R2 RAC on Oracle Virtual Machines

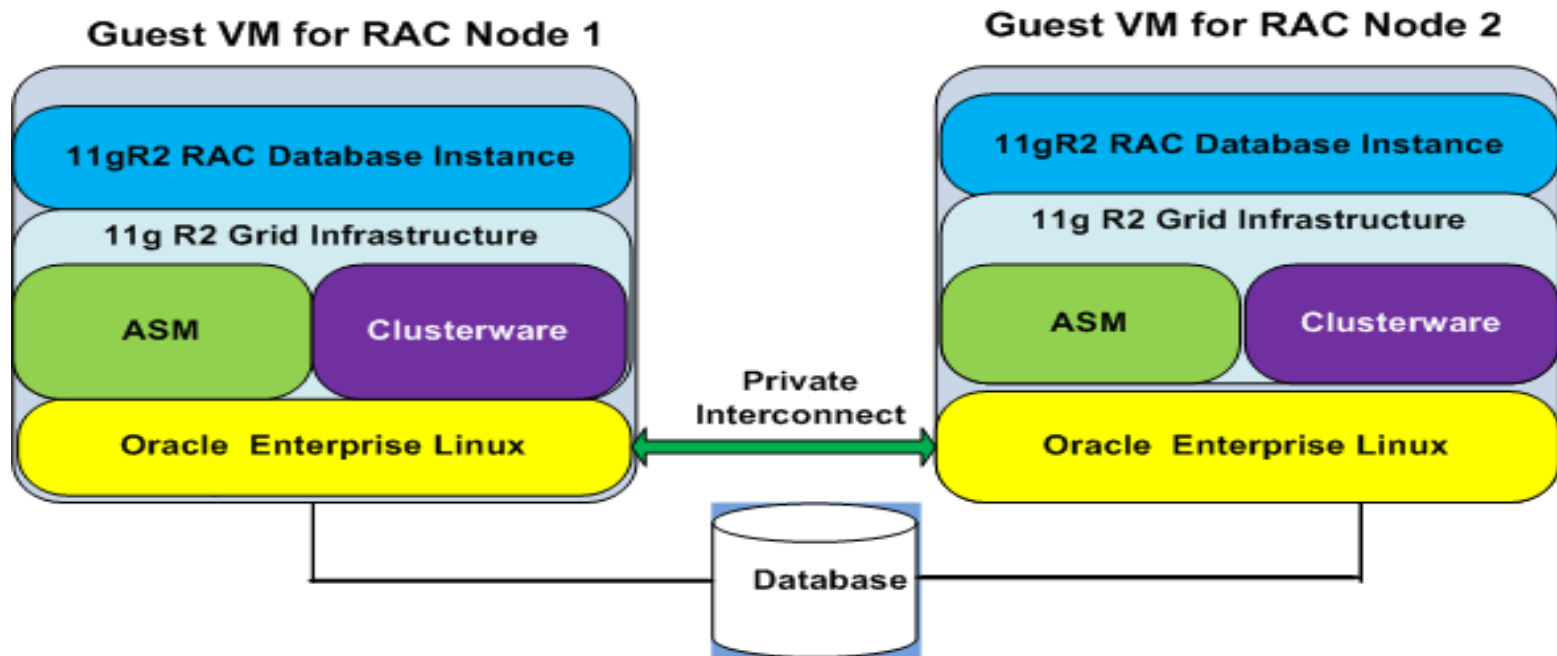

Introduction to Oracle VM and RAC

- Requirements and certifications of RAC on Oracle VM
 - Prod: 2 VM servers, NICs for Network & Storage
 - Dev/Test: 1 VM server, external storage not required
 - Certified RAC versions: 10.2.0.4 and up, 32/64 bit
 - Supported OVM version: 2.1.2 and up
- Virtual CPU/Memory configuration for RAC
 - Assigned the virtual CPUs, Memory for VM: vm.cfg :
vcpu=2', memory = 8192
 - Hard partitioning, CPU pinning: cpu='0-3' or cpu='0,1'
 - Not recommended over-commit CPUs
 - Rules for VCPU allocations*:
 - 1 VCPU for each core to dom-0
 - Total VCPUs for alls guests VM $\leq 2 * \text{real CPUs VM server}$
 - # of VCPU of a guest VM $\leq \#$ of real CPUs of VM server
 - CPU pinning only used for hard partitioning

* Oracle Real Applications Clusters in Oracle VM Environments
Oracle whitepaper, June 2010

Configuring Oracle VM Infrastructure

- Architecture Overview:

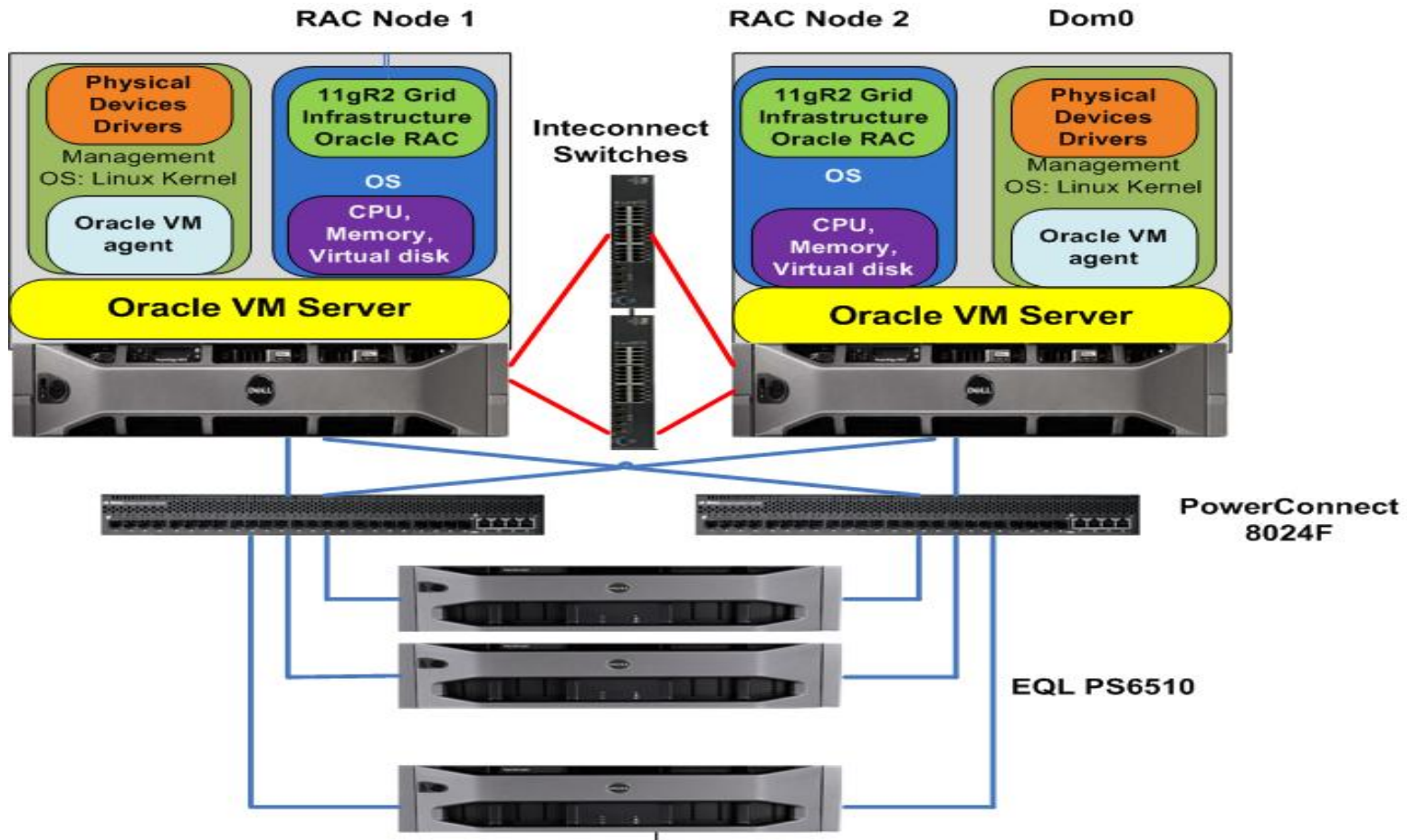

- Tasks:
 - 1) Configure VM infrastructure
 - 2) Configure VMs
 - 3) Install Oracle RAC on VMs.

Configuring Oracle VM Infrastructure

- Implementation Tasks Overview
 - Virtual servers Installation
 - Virtual server network and storage configuration.
 - Connect VM servers to the VM Manager
 - Create guest VM using VM template
 - Configure network and shared storage on VMs
- Virtual Server Installation
 - Prepare local disk and enable virtualization on BIOS
 - Install Oracle VM server OVM 2.2
 - Change Dom0 memory : /boot/grub/menu.lst:
edit line: *kernel /xen-64bit.gz dom0_mem=1024M*
 - Ensure VM agent working: *#service ovs-agent status*

Configuring Oracle VM Infrastructure

- VM server network configure
 - OVM is based on Xen network infrastructure
Physical NIC <-> Xen bridge <-> virtual NIC of VM
default each physical NIC has an Xen bridge.
 - For oracle RAC environment, we need to reconfigure it

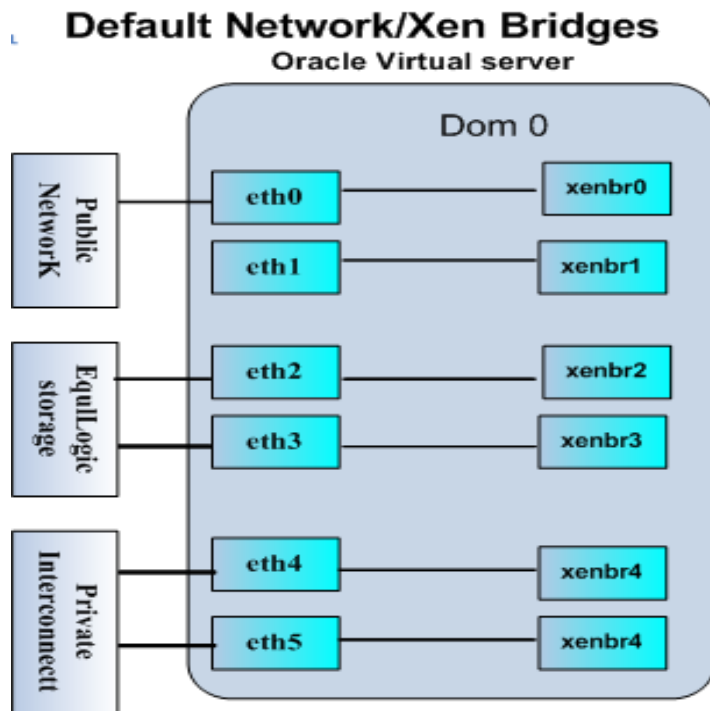

VM server network reconfiguration:
a. Shutdown the default Xen bridges:
`/etc/xen/scripts/network-bridges stop`

b. Disable the default Xen bridges
put the network-dummy script:
`#!/bin/bash /bin/true`
in `/etc/xen/script`, replace line
(`network-script network-bridges`)
with
(`network-script network-dummy`)
in `/etc/xen/xend-config.sxp`

Configuring Oracle VM Infrastructure

- Manually configure Network Interfaces NIC of VM

```
DEVICE=eth0
HWADDR=00:25:64:FB:08
:2C
BRIDGE=xenbr0
```

```
DEVICE=xenbr0
BOOTPROTO=none
TYPE=Bridge
IPADDR=155.16.9.91
```

```
DEVICE=eth4
HWADDR=00:25:64:FB:08:30
MASTER=bond0
SLAVE=yes
```

```
DEVICE=eth5
HWADDR=00:25:64:FB:08:30
MASTER=bond0
SLAVE=yes
```

```
DEVICE=bond0
ONBOOT=yes
BOOTPROTO=none
BRIDGE=xenbr1
```

```
DEVICE=xenbr1
ONBOOT=yes
TYPE=Bridge
BOOTPROTO=none
IPADDR=192.168.9.91
```

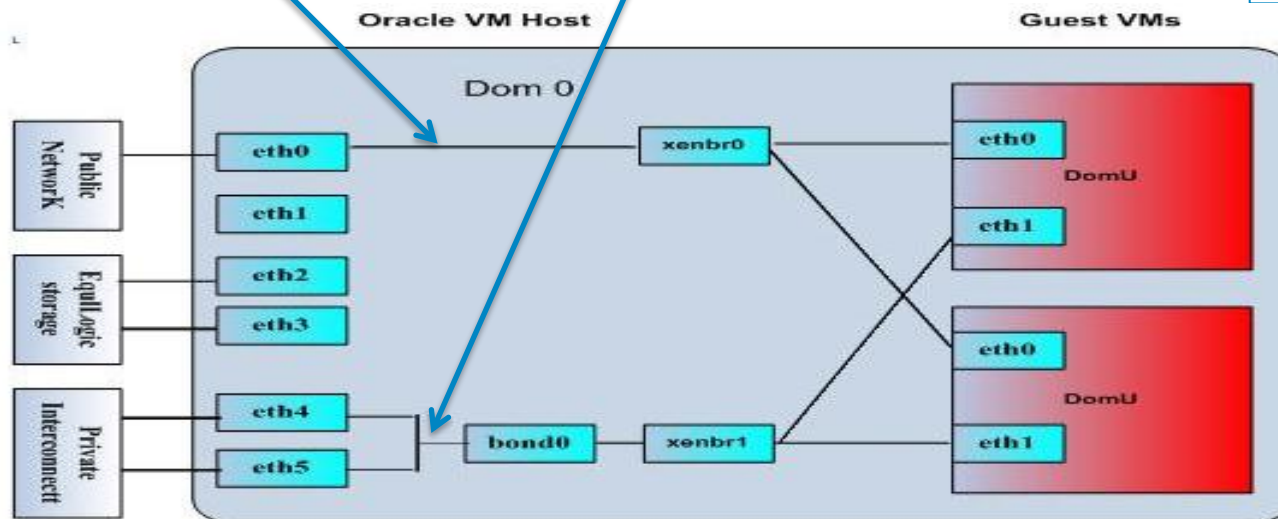

Configuring Oracle VM Infrastructure

- VM Shared Storage Configuration
- Create Shared storage volume in ISCSI SAN:

Volume	Size	Raid	Used for	OS Mapping
OVS	2000GB	10	VM Repository	/OVS
owidata1	1000GB	10	OWI Database	ASM diskgroup
owifra1	500GB	10	OWI FRA	ASM diskgroup
racbdbdata1	100GB	10	racdb Database	ASM diskgroup
racdbfra1	50GB	10	racdb fra	
OCR1	1GB	10	OCR/Votingdisk	ASM diskgroup
OCR2	1GB	10	OCR/Votingdisk	ASM diskgroup
OCR3	1GB	10	OCR/Votingdisk	ASM diskgroup
OCR4	1GB	10	OCR/Votingdisk	ASM diskgroup
OCR5	1GB	10	OCR/Votingdisk	ASM diskgroup

Configuring Oracle VM Infrastructure

- VM Shared Storage Configuration.
 - Configure iSCSI Connections to the storage volumes

```
$iscsiadm -m iface -l ieth2--op=new
```

```
$iscsiadm -m iface -l ieth2 --op=update -n iface.net_ifacename -v eth2
```

```
$iscsiadm -m discovery -t st -p 10.16.7.15 --interface=ieth2 --interface=ieth3
```

```
$iscsiadm -m node -p 10.16.7.15 --interface ieth2--login
```

```
$ iscsiadm -m node -p 10.16.7.15 --interface ieth3 --login
```

- Configure device mapper multipaths to volumes

```
edit /etc/multipath.conf :
```

```
  multipath {
```

```
    wwid
```

```
    36090a068b0bc14240abe94020000204e
```

```
    alias          ovs
```

```
  }
```

```
$service multipathd restart
```

```
$ls /dev/mapper/*
```

```
acfs ocr1, ocr2, ocr3, cor4, ocr5, ovs owidata1 owifra1 racdata1  
racfra1
```

Configuring Oracle VM Infrastructure

- Create VM repository
 - Create OCFS2 cluster file system on OVS volume
configure O2cb server on each node: `$service o2cb configure`
create a partition on the volume: `$fdisk /dev/mapper/ovs`
Create OCFS file system on the partition
`$ mkfs.ocfs2 -T datafiles -N 8 -L "OVS" /dev/mapper/ovsp1`
 - Create VM repository
delete the default local repository:
`$/opt/ovs-agent-2.3/utils/repos.py -d /dev/sda3`
create the new VM repository on the shared storage:
`$/opt/ovs-agent-2.3/utils/repos.py -n /dev/mapper/ovsp1`
Get the uuid(Universal Unique Identifier) of the storage repository
`$/opt/ovs-agent-2.3/utils/repos.py -l`
`[] 226b143f-9579-4c66-adc2-2def917e97e3 => /dev/mapper/ovsp1`
make the newly created repository the cluster root repository `$/opt/ovs-agent-2.3/utils/repos.py -r 226b143f-9579-4c66-adc2-2def917e97e3`
- `[R] 226b143f-9579-4c66-adc2-2def917e97e3 => /dev/mapper/ovsp1`
Check: `/opt/ovs-agent-2.3/utils/repos.py -l`
`[R] 226b143f-9579-4c66-adc2-2def917e97e3 => /dev/mapper/ovsp1`

Configuring Oracle VM Infrastructure:

- Oracle VM Manager
 - Web based GUI console to simplify VM management
 - Manages VM servers, VM sever pool, VMs, migration..
 - Talk to VM agent running each VM server.
- Create VM server pool.
 - Start OVS agent: `#service ovs-agent start`
 - Create VM server pool

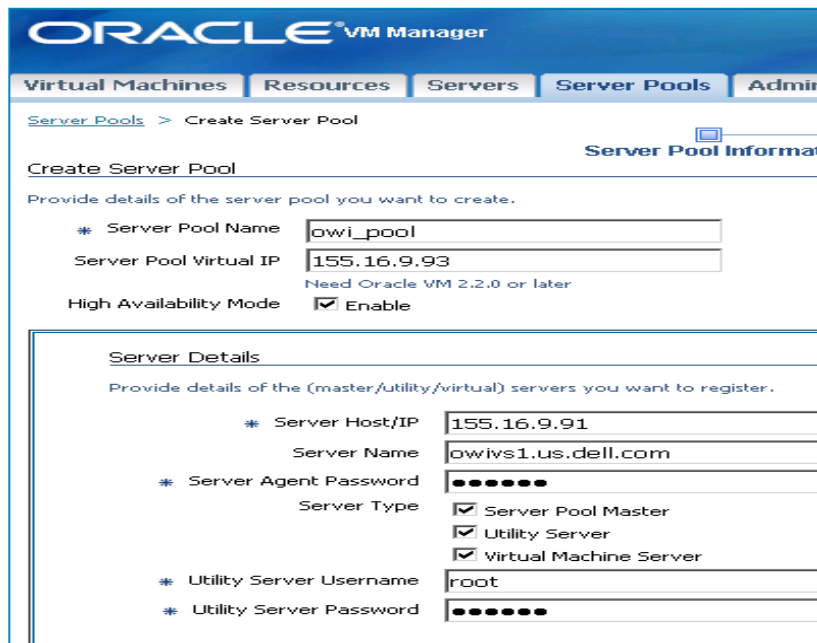

The screenshot shows the Oracle VM Manager web interface. The top navigation bar includes 'Virtual Machines', 'Resources', 'Servers', 'Server Pools', and 'Admin'. The main content area is titled 'Create Server Pool' and contains two sections: 'Create Server Pool' and 'Server Details'. In the 'Create Server Pool' section, the 'Server Pool Name' is 'owiv_pool', the 'Server Pool Virtual IP' is '155.16.9.93', and 'High Availability Mode' is checked. The 'Server Details' section includes fields for 'Server Host/IP' (155.16.9.91), 'Server Name' (owivs1.us.dell.com), 'Server Agent Password' (masked), and 'Server Type' (checked for 'Server Pool Master', 'Utility Server', and 'Virtual Machine Server'). It also includes fields for 'Utility Server Username' (root) and 'Utility Server Password' (masked).

```
root@owivs1 ~]# df -k
Filesystem      1K-blocks  Used Available Use% Mounted on
/dev/sda2       3050092   851660 2040996 30% /
/dev/sda1       101086   45826  50041 48% /boot
tmpfs           524372    0  524372  0% /dev/shm
/dev/mapper/ovsp1 2097157120 358400 2096798720 1%
/var/ovs/mount/226B143F95794C66ADC22DEF917E97E3
[root@owivs1 ~]# ls -lra /OVS
lrwxrwxrwx 1 root root 47 May11 09:56 OVS ->
/var/ovs/mount/226B143F95794C66ADC22DEF917E97E3
```

Configuring Oracle VM Infrastructure

- Add an additional VM server to the VM server pool
 - Install VM server, prepare the network and storage access
 - Start OVS agent, accessible from VM manager
 - Configure oc2b service
 - Add the VM server to the VM server pool

Add Server

Server Details

Provide details of the (utility/virtual) servers you want to register.

* Server Host/IP:

Server Name:

* Server Agent Password:

* Server Type: Utility Server
 Virtual Machine Server

* Server Pool Name:

```
[root@owivs2 ocfs2]# more cluster.conf
node:
  ip_port = 7777
  ip_address = 155.16.9.92
  number = 0
  name = owivs2.us.dell.com
  cluster = ocfs2
node:
  ip_port = 7777
  ip_address = 155.16.9.91
  number = 1
  name = owivs1.us.dell.com
  cluster = ocfs2]
cluster:
  node_count = 2
  name = ocfs2
```

Select and	Reboot	Power Off	Edit	Delete	Set Maintenance			
Select	Server Host/IP	Server Name	Server Type	Status	Server Location	Server Pool Name		
<input checked="" type="radio"/>	155.16.9.91	owivs1.us.dell.com	Server Pool Master,Utility Server,Virtual Machine Server	Active		owi_pool		
<input type="radio"/>	155.16.9.92	owvs2.us.dell.com	Virtual Machine Server	Active		owi_pool		

Configuring Oracle VM Infrastructure

- OVS Repository
 - Device and file system point

```
[root@owivs1 running_pool]# df -k | grep ovs
/dev/mapper/ovspl      2097157120 1725336576 371820544   83% /var/ovs/mount/226B143F95794C66ADC22DEF917E97E3
[root@owivs1 running_pool]#
[root@owivs1 running_pool]# ls -l /OVS
lrwxrwxrwx 1 root root 47 Jun 27 10:18 /OVS -> /var/ovs/mount/226B143F95794C66ADC22DEF917E97E3
[root@owivs1 running_pool]#
```

- What are inside of OVS repository
 - /OVS/running_pool: all the VM images
 - /OVS/seed_pool : VM templates

```
[root@owivs1 ~]# ls /OVS
iso_pool      publish_pool  seed_pool
lost+found    running_pool  sharedDisk
[root@owivs1 ~]#
[root@owivs1 ~]# ls -l /OVS/running_pool/
total 0
drwx----- 2 root root 3896 Apr 19 12:33 103_gfstestapps
drwx----- 2 root root 3896 Nov 16 2010 109_gfstestdb
drwxrwxrwx 2 root root 3896 Jul 1 12:12 15_owil
drwxrwxrwx 2 root root 3896 Nov 22 2010 21_owi
```

Configuring Oracle Guest VMs for RAC

- Create Virtual Machines
 - Import OEL VM template: OVM_EL5U5_X86_64_PVM_10GB

The screenshot shows the 'General Information' tab of the Oracle VM configuration wizard. The fields are as follows:

* Server Pool Name:	owi_pool
* Virtual Machine Template Name:	OVM_EL5U5_X86_64_PVM_10GB
* Operating System:	Red Hat Enterprise Linux 5 64-bit
* Virtual Machine System Username:	root
* Virtual Machine System Password:	*****
Description:	

The screenshot shows the 'Virtual Machine' tab of the Oracle VM configuration wizard. The options are:

- Create virtual machine based on virtual machine template
- Create from installation media
- Create a network bootable virtual machine(pxeboot)

- Create VM using the VM template

The screenshot shows the summary screen of the Oracle VM configuration wizard. The details are as follows:

Virtual Machine Name:	owi2
Enable High Availability:	false
Virtual Machine Templates	
Template Name:	OVM_EL5U5_X86_64_PVM_10GB
Size (MB):	12700
Status:	Active
Server Pool	
Server Pool Name:	owi_pool
Status:	Active
Preferred Server:	Manual

Buttons: Previous, Confirm

Configuring Oracle Guest VMs for RAC

Virtual Machine Name:

Console Password:

Confirm Console Password:

High Availability

Enable High Availability:

Network Interface Card

Select and

Select	Virtual Network Interface Name	Virtual Network Interface MAC Address	Bridge
<input checked="" type="radio"/>	VIF0	00:16:3E:19:31:39	xenbr0
<input type="radio"/>	VIF1	00:16:3E:13:BB:1C	xenbr1

Virtual Machines

Select and More Actions:

Select	Virtual Machine Details	Memory Size (MB)	Status	Owner Group Name	Server Name	Server Pool Name
<input checked="" type="radio"/>	+ Show owi	2,048	Powered Off	admin My Workspace	N/A	owi_pool
<input type="radio"/>	+ Show 15 owi1	2,048	Running	admin My Workspace	owvs2.us.dell.com	owi_pool

- Configure Network on Virtual Machines
 - eth0 for public network on xenbr0,
 - eth1 for private network on xenbr1
- vm.cfg:

```
vif = ['bridge=xenbr0,mac=00:16:3E:36:8A:53,type=netfront',  
      'bridge=xenbr1,mac=00:16:3E:3A:8F:CC,type=netfront', ]
```

Configuring Oracle Guest VMs for RAC

- Configure shared storage for Virtual Machines

```
disk =  
[file:/var/ovs/mount/226B143F95794C66ADC  
22DEF917E97E3/running_pool/30_ow  
i2/System.img,xvda,w!,  
'phy:/dev/mapper/ocr1p1,xvdc,w!',  
'phy:/dev/mapper/ocr2p1,xvdd,w!',  
'phy:/dev/mapper/ocr3p1,xvde,w!',  
'phy:/dev/mapper/ocr4p1,xvdf,w!',  
'phy:/dev/mapper/ocr5p1,xvdg,w!',  
'phy:/dev/mapper/owidata1p1,xvdh,w!',  
'phy:/dev/mapper/owidata2,xvdi,w!',  
'phy:/dev/mapper/owidata3,xvdj,w!',  
'phy:/dev/mapper/owidata4,xvdk,w!',  
'phy:/dev/mapper/owidata5,xvdl,w!',  
'phy:/dev/mapper/owifra1p1,xvdm,w!',  
'phy:/dev/mapper/owifra2,xvdn,w!',  
]
```

```
/root  
[root@owirac2 ~]# more /proc/partitions  
major minor #blocks name  
202 0 13004617 xvda  
202 1 96358 xvda1  
202 2 10803712 xvda2  
202 3 2104515 xvda3  
202 32 3132643 xvdc  
202 48 3132643 xvdd  
202 64 3132643 xvde  
202 80 3132643 xvdf  
202 96 3132643 xvdg  
202 112 1048578583 xvdh  
202 128 1048578583 xvdi  
202 144 1048578583 xvdj  
202 160 1048578583 xvdk  
202 176 1048578583 xvdl  
202 192 524297308 xvdm  
202 208 524297308 xvdn  
[root@owirac2 ~]# █
```

Configuring Oracle Guest VMs for RAC

- Add local disks to guest VMs: default local disk image size of the template is 10GB. Need to attach additional virtual local disk for swap

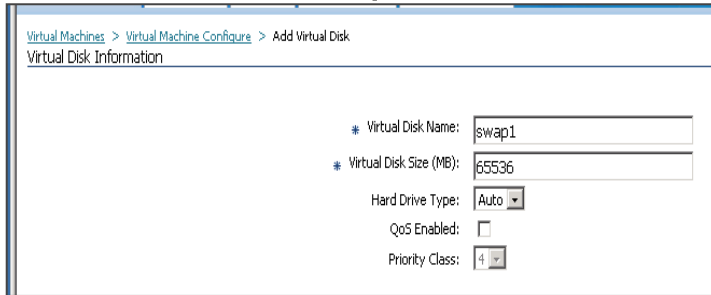

Select	Virtual Disk Name	Size (MB)	Front-end Device	Hard Disk Driver	QoS Enabled	Priority Class
<input type="radio"/>	System	12,700	xvda	Auto	N	N/A
<input type="radio"/>	swap1	65,536		Auto	N	N/A

```

/proc/partitions has a new 654 GB virtual device xvdp in VMs
fdisk /dev/xvdp to make a partition /dev/xcdvp1
$mkswap /dev/xvdp1          $swapon /dev/xvdp1
    
```

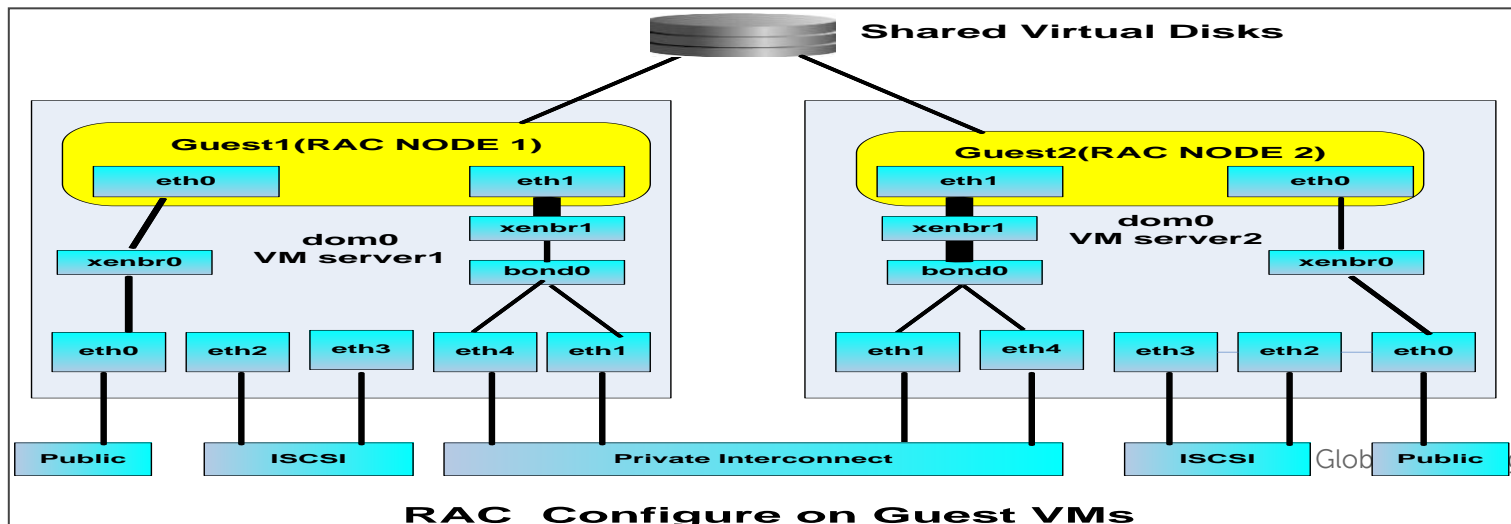

Configuring 11g R2 RAC Database on OVM

- Methods to create Oracle RAC Database on OVM
 - Manual Installation and configuration
 - Automated Provisioning using EM Provisioning Procedure
 - Based on Oracle RAC 11g R2 Oracle VM Template: refer to Saar's [Power of the New Oracle RAC 11g Release 2 Oracle VM Templates](#)
- Installing & configuring Oracle RAC OVM
 - Network configuration: private, private, SCAN IPs, VIPs
 - Disable firewall service: `$service iptables stop`
`$chkconfig iptables off`
 - Prerequisite checks: rpms, kernel configs, ntpd, etc
limits in /etc/security/limits.conf for grid user and oracle user
`./runcluvfy.sh stage -pre crsinst -n owirac1,owirac2 -r 11gR2 -verbose`
 - Create ASM disks on the virtual disks:
`$service oracleasm configure -- configure ASM (all nodes)`
`$fdisk /dev/xvdc, kpartx /dev/xvdc -- partition virtual disks`
`$service oracleasm createdisk OCR1 /dev/xvdc1 (all nodes)`
- fix issue :

Configuring 11g R2 RAC Database on OVM

- Install 11gR2 Grid Infrastructure = Clusterware + ASM

Oracle Grid Infrastructure - Setting up Grid Infrastructure - Step 1 of 8

Select Installation Option

ORACLE 11g DATABASE

Select any of the following installation options

- Install and Configure Grid Infrastructure for a Cluster
- Install and Configure Grid Infrastructure for a Standalone Server
- Upgrade Grid Infrastructure
- Install Grid Infrastructure Software Only

Oracle Grid Infrastructure - Setting up Grid Infrastructure - Step 4 of 16

Grid Plug and Play Information

ORACLE 11g DATABASE

Single Client Access Name (SCAN) allows clients to use one name in connection strings to connect to the cluster as a whole. Client connect requests to the SCAN name can be handled by any cluster node.

Cluster Name:

SCAN Name:

SCAN Port:

Configure GNS

GNS Sub Domain:
For example: grid.example.com

GNS VIP Address:

Configuring 11g R2 RAC Database on OVM

- Specify the network interfaces:

Specify Network Interface Usage

Identify the planned use for each global interface shown in the box below as Public, Private, or Do Not Use. Private interfaces are used by Oracle Grid Infrastructure for internode traffic.

If there is more than one subnet associated with an interface, then change the interface's attributes to associate the interface name with the additional subnets.

Interface Name	Subnet	Interface Type
eth0	155.16.0.0	Public
eth1	192.168.9.0	Private

- Specify ASM disks for OCR and Votingdisk files:

Storage Option Information

You can place Oracle Cluster Registry (OCR) disks and voting disks on ASM storage or on a file system.

Automatic Storage Management (ASM)
Choose this option to configure OCR and voting disks on ASM storage.

Shared File System
Choose this option to configure OCR and voting disks on an existing shared file system.

Create ASM Disk Group

Select Disk Group Characteristics and select disks

Disk Group Name:

Redundancy: High Normal External

Add Disks

Candidate Disks All Disks

	Disk Path	Size (in MB)	Status
<input checked="" type="checkbox"/>	ORCL:OCR1	980	Candidate
<input checked="" type="checkbox"/>	ORCL:OCR2	980	Candidate
<input checked="" type="checkbox"/>	ORCL:OCR3	980	Candidate
<input checked="" type="checkbox"/>	ORCL:OCR4	980	Candidate
<input checked="" type="checkbox"/>	ORCL:OCR5	980	Candidate

troubleshooting: `/usr/sbin/oracleasm-discover 'ORCL:*`

Configuring 11g R2 RAC Database on OVM

The screenshot shows the Oracle 11g Database OVM progress window. The progress bar is at 100%. A dialog box titled "Execute Configuration scripts" is open, displaying the following information:

The following configuration scripts need to be executed as the "root" user in each cluster node.

Scripts to be executed:

Number	Script Location	Nodes
1	/u01/app/11.2.0/grid/root.sh	owirac1,owirac2

To execute the configuration scripts:

1. Open a terminal window
2. Log in as "root"
3. Run the scripts in each cluster node
4. Return to this window and click "OK" to continue

Run the script on the local node first. After successful completion, you can run the script in parallel on all the other nodes.

On the right side of the dialog, a status list shows: Succeeded, Succeeded, Succeeded, Succeeded, Succeeded, Succeeded, In Progress, Pending.

Install Oracle RAC software

```
./cluvfy stage -pre dbinst -fixup -n owirac1,owirac2 -r  
11gR2 -osdba dba -verbose
```

./runInstaller as Oracle user

Select two RAC nodes

Select the software location

Configuring 11g R2 RAC Database on OVM

- Create ASM diskgroups for Database as grid user: `./asmca`

Create Disk Group

Disk Group Name: DATA

Redundancy: High Normal **External (None)**

Select Member Disks: Show Eligible Show All

Quorum failure groups are used to store voting files in extended clusters and do not contain disks with a compatibility of 11.2 or higher.

<input type="checkbox"/>	Disk Path	Header Status	Disk Name	Size (MB)
<input checked="" type="checkbox"/>	ORCL:DATA1	PROVISIONED		1024002
<input checked="" type="checkbox"/>	ORCL:DATA2	PROVISIONED		1024002
<input checked="" type="checkbox"/>	ORCL:DATA3	PROVISIONED		1024002
<input checked="" type="checkbox"/>	ORCL:DATA4	PROVISIONED		1024002
<input checked="" type="checkbox"/>	ORCL:DATA5	PROVISIONED		1024002
<input type="checkbox"/>	ORCL:FRA1	PROVISIONED		512009
<input type="checkbox"/>	ORCL:FRA2	PROVISIONED		512009

Note: If you do not see the disks which you believe are available, check Disk Discovery Path. The Disk Discovery Path limits set of disks considered for discovery.

Create Disk Group

Disk Group Name: FRA

Redundancy: High Normal **External (None)**

Select Member Disks: Show Eligible Show All

Quorum failure groups are used to store voting files in extended clusters and do not contain disks with a compatibility of 11.2 or higher.

<input type="checkbox"/>	Disk Path	Header Status	Disk Name	Size (MB)
<input checked="" type="checkbox"/>	ORCL:FRA1	PROVISIONED		512009
<input checked="" type="checkbox"/>	ORCL:FRA2	PROVISIONED		512009

- Create RAC database : `./cluvfy stage -pre dbcfg -fixup -n owirac1,owirac2, -d $ORACLE_HOME -verbose`
run `./dbca` as oracle
Select Oracle Real Application Clusters database
Select two RAC nodes
Select +DATA for database area, +FRA for flash recovery area
Specify the database configuration

Provision RAC With EM Provisioning Pack

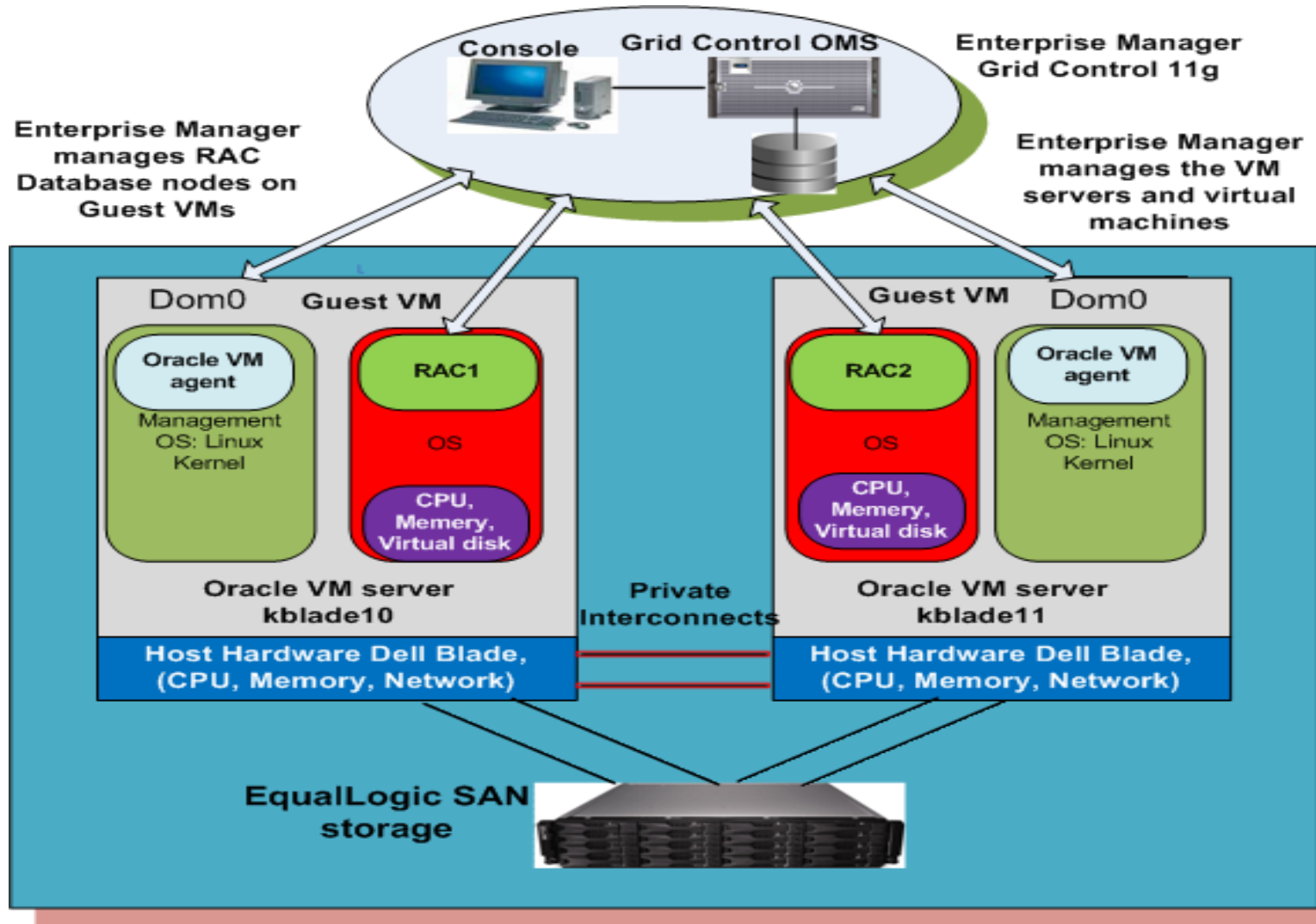

Provision RAC with EM Provisioning PACK

Manage Virtual Environment through Enterprise Manager

Select	Name [△]	Type	Status	Pool	Server	System	AI
<input type="checkbox"/>	kblade10.us.dell.com	Virtual Server	↑	kblade vm pool		Oracle VM server release 2.2.0	
<input type="checkbox"/>	kblade11.us.dell.com	Virtual Server	↑	kblade vm pool		Oracle VM server release 2.2.0	
<input type="checkbox"/>	kblade vm pool	Virtual Server Pool	↑			Oracle VM server release	

Name [△]	Type	Status	Server Pool	Virtual Server	Operating System
RAC1	Guest VM	Running	kblade vm pool	kblade10.us.dell.com	Enterprise Linux Enterprise Linux Server release 5.5 (Carthage)
RAC2	Guest VM	Running	kblade vm pool	kblade11.us.dell.com	Enterprise Linux Enterprise Linux Server release 5.5 (Carthage)

Manage Guest VM OS and RAC database

Select	Name [△]	Status	Alerts	Policy Violations
<input checked="" type="radio"/>	vmrac1.us.dell.com	↑	0 0	10 0 0
<input type="radio"/>	vmrac2.us.dell.com	↑	0 2	17 0 0

Provision RAC with EM Provisioning PACK

Provisioning 11g R2 RAC Database

Deployment Procedure Manager	
Getting Started with Deployment Procedure Manager	Procedure Completion Status
Deployment Procedures	Application Server Provisioning Procedures
Database Provisioning Procedures	RAC Provisioning Procedures
Extend Cluster Database	Patch Procedures

View Schedule Deployment... Edit Create Like Revert Delete Upload						
Select	Procedure	Type	Description	Last Modified By	Version	Last Updated
<input checked="" type="radio"/>	Oracle Grid Infrastructure / RAC Provisioning	RAC Provisioning	Provisions Oracle Grid Infrastructure 11g Release 2 (11.2) and Oracle Real Application Clusters 11g Release 2 (11.2) for clustered environments. ⓘ	Oracle	6.1	May 24, 2010 1:42:21 AM CDT
<input type="radio"/>	Oracle Clusterware / RAC Provisioning For UNIX	RAC Provisioning	This procedure assists in installing/cloning and configuring a cluster database (a Real Application Cluster - RAC database) on a selection of hosts as specified by the Oracle Database Oracle Clusterware and Oracle Real Application Clusters Installation Guide. ⓘ	Oracle	6.1	May 24, 2010 1:42:21 AM CDT

For details, refer to my Oracle OpenWorld 2010 Presentation: [Oracle RAC on Oracle VM Automated Provisioning with Oracle Enterprise Manager 11g](#): Session ID #S316218

Recorded Demo: Oracle 11g R2 RAC on OVM

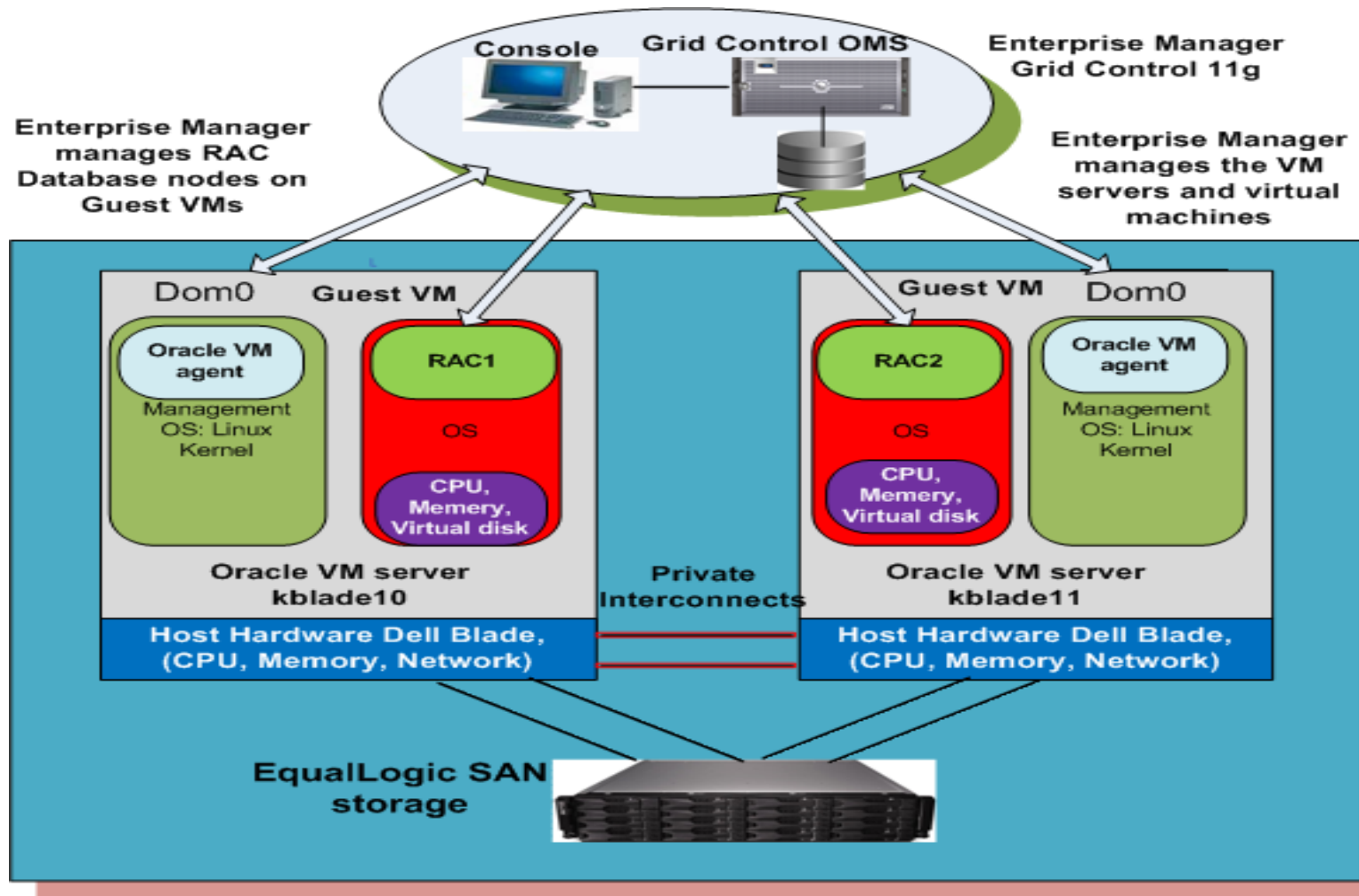

Thank You and QA

Visit my Oracle Blog at <http://kyuoracleblog.wordpress.com>

Oracle ACE Director Kai Yu's Oracle Blog

Share Oracle Tips and Tricks and Related News



[About Me](#) [Presentations](#) [Publications](#) [Resources](#)

About Me



My name is Kai Yu. I am a senior system engineer/consultant architect in Dell Oracle Solutions engineering lab. I have been working on Oracle technologies since 1995. My involvement with Oracle Technologies really came from two different prospects: as a hardcore Oracle Database administrator and Oracle Applications DBA in various IT departments 1995-2006 and as an Oracle solutions architect and system engineer since 2006 while I focus on design and architecting

I AM A MEMBER OF



ARCHIVES

- [July 2011](#)
- [June 2011](#)
- [May 2011](#)
- [April 2011](#)